

The Effects of Reflector Design and Lamp Orientation

The orientation of the lamp and the design of the reflector influence the performance characteristics of the light source in the following ways:

Optical Power

The obvious way to increase the optical output of a light source is to employ a bigger lamp. A higher power lamp, however, will not necessarily result in higher optical output from a light source. Since light is emitted by the lamp in all directions, the important thing is not the amount of light emitted, but the amount of light *collected*.

The A-1010B and the A-6000 have the highest optical power output because they have the highest collection efficiency. They collect and focus emitted light with a single optical element: an ellipsoidal reflector. Because the ellipsoid encloses a large portion of the solid angle about the arc lamp, over 65% of the lamp's emission is collected and focussed at the output.

Compare this to the typical performance of a traditional lamp housing design, such as that used in the A-500, where roughly 10% of the light is collected. Using identical lamps, the total optical output of the A-1010B is about seven times higher than the A-500. To get the same optical output as a A-1010B with a 100 watt lamp, a traditional housing would require a 1000 watt lamp!

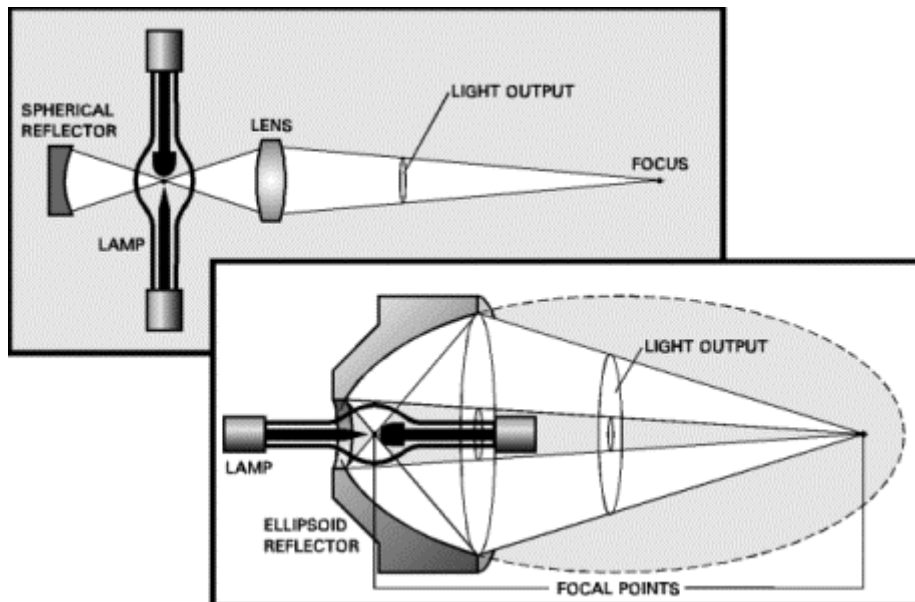

An ellipsoid has two focal points. With the arc lamp precisely positioned at one focal point, the collected light is focussed at the second focal point. In your experiment, the sample, the monochromator slit or the fiber optic bundle would be positioned at the second focal point.

Power Density

For many experiments involving the illumination of a relatively small area, the power density of a light source is a critical specification. Optical power density is a function of the output of the lamp and the size of the area illuminated. Note, however, that increasing the lamp power does not necessarily increase the power density; in fact, it can actually reduce it. Assuming the optics are the same, the maximum practical power density is a function of arc size.

For example, a 75 watt lamp has a luminous area of 0.2 by 0.5 mm, or 0.1 sq. mm. A typical 450 watt lamp has a luminous area of 0.9 by 2.7 mm, or 2.43 sq. mm. The illuminated area from the 450 watt lamp is 24 times greater than the 75 watt lamp, but it has only six times more power. The power density of the 75 watt lamp, then, is *four times higher* than that of the 450 watt lamp.

Stability

The interior of an arc lamp housing in operation can exceed 150 degrees celcius. Thermal distortion of the reflector is of concern, since it is the only optical element in the system. Deformation of the ellipsoid shape can dramatically reduce the useable output of the illuminator. The proprietary, thermally-matched optics of the A-1010B and A-6000 guarantee that the shape of the ellipsoidal reflector remains accurate during operation.

Uniformity

Neither a vertical nor a horizontal arc lamp produces perfectly uniform illumination. The majority of the light is produced near the cathode. When mounted vertically, the illumination between the electrodes is quite uneven from top to bottom. In the horizontal position, convection currents within the lamp cause slight arc wander. We have found that the ellipsoidal reflector produces the most consistent intensity at the output when the lamp is operated in the horizontal position.

United States: 300 Birmingham Road, P.O. Box 272 Birmingham NJ 08011 Phone: 609-894-4420 Fax: 609-894-1579

Canada: 347 Consortium Court, London, Ontario, N6E 2S8 Phone: (519) 668-6920 Fax: (519) 668-8437

United Kingdom: Unit M1, Rudford Ind'l Est., Ford Rd, Ford, West Sussex BN18 0BF Phone: +44 (0) 1903 719 555 Fax: +44 (0) 1903 725 772

Germany: PhotoMed GmbH, Buero Sued, Inninger Str. 1, 82229 Seefeld Phone: +49-8152-993090 Fax: +49-8152-993098

Denmark: PhotoMed GmbH, Sondre Alle, DK-4600 Koge Phone: +45 56 66 33 86 Fax: +45 56 66 33 81

VIST US ONLINE AT WWW.PTI-NJ.COM

Copyright© 2005 Photon Technology International, Inc. All Rights Reserved. PTI is a registered trademark of Photon Technology International, Inc. Specifications are subject to change without notice. Rev. A